

NOTES:

1. TO INSPECT ASSEMBLY, FOLLOW FIRST ARTICLE AND IN PROCESS INSPECTION SHEET.

BILL OF MATERIAL (CURRENT LEVEL)

ITEM	PT/ASSY	DESCRIPTION	TYPE	QTY.
1	10050	ESCUTCHEON WALL VALVE	PART	1
2	91753	O-RING, # 2-136, EP, 50 DURO - GREY	PART	1
3	10523	HEX ESCUTCHEON BONNET	PART	1
4	2-436	LEVER HANDLE ASM	ASSEMBLY	1

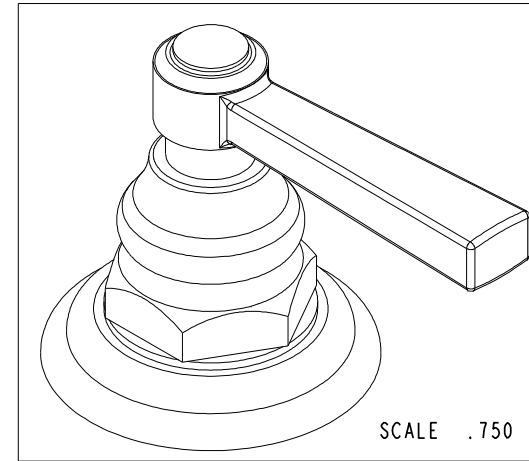
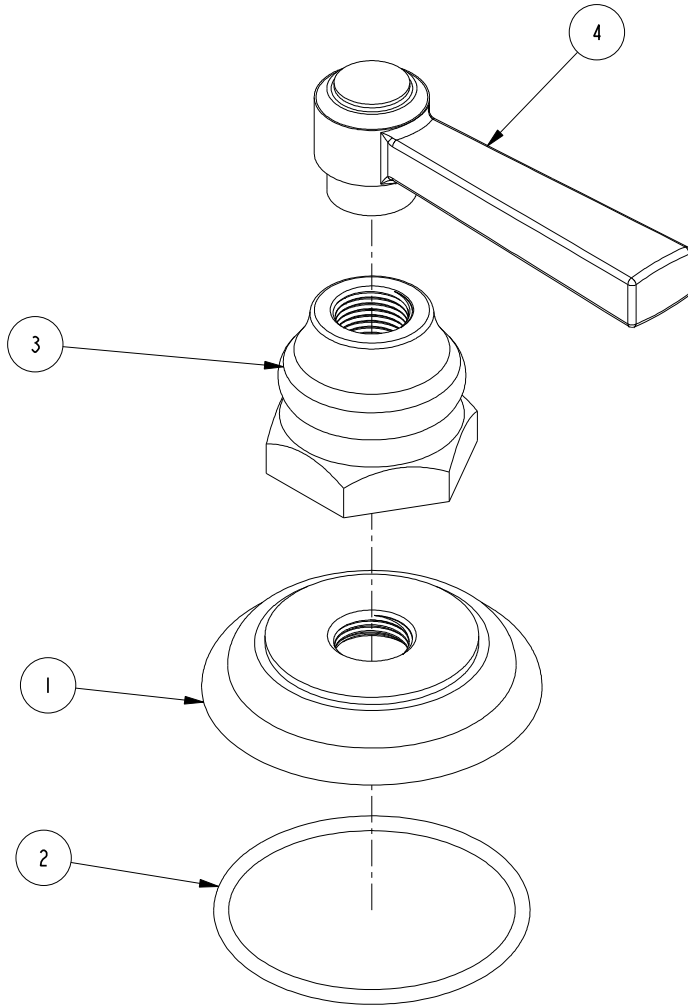

ZONE	REV	DESCRIPTION	DATE	APPROVED
-	C	EN-4300j	12/16/20	R.S.
-	B	EN-3722	02/08/19	C.G.
-	A	EN-2621B	02/28/14	-
-	-	EN-2621	11/21/13	-

COPYRIGHT 2005 BRASSTECH, INC. THESE DRAWINGS AND THE DESIGNS DEPICTED HEREIN ARE THE PROPRIETARY PROPERTY OF BRASSTECH. ANY USE OR REPRODUCTION IS SUBJECT TO THE EXPRESS APPROVAL OF BRASSTECH. UNAUTHORIZED USE IS STRICTLY PROHIBITED. ALL RIGHTS RESERVED.

TESTING	-	-	-
ASSEMBLY	-	-	-
PLATING	-	3-911	3-911
POLISHING	-	NEXT ASSY	USED ON
MACHINING	-	APPLICATION	
TOOLING FIXTURE #	REMOVE ALL BURRS AND SHARP EDGES		

UNITS ARE: INCHES [MM]
 TOLERANCES ARE:
 FRACTIONS DECIMALS ANGLES
 $\pm 1/16"$.X $\pm .1$ [2.5] $\pm 1^\circ$
 .XX $\pm .06$ [1.5]
 (X.XXX) DENOTES CRITICAL DIMS.
 ALL THREADS ARE CRITICAL
 DRAWN JIMSON 12/16/20
 CHECKED R.S. 12/16/20
 APPROVED R.S. 12/16/20

BRASSTECH 2001 CARNEGIE AVE.
 INCORPORATED SANTA ANA, CA 92705
 (949) 417-5207

HANDLE ASM

DWG NO. **3-343** REV **C**

SCALE .750 REF. - SHEET 1 OF 2

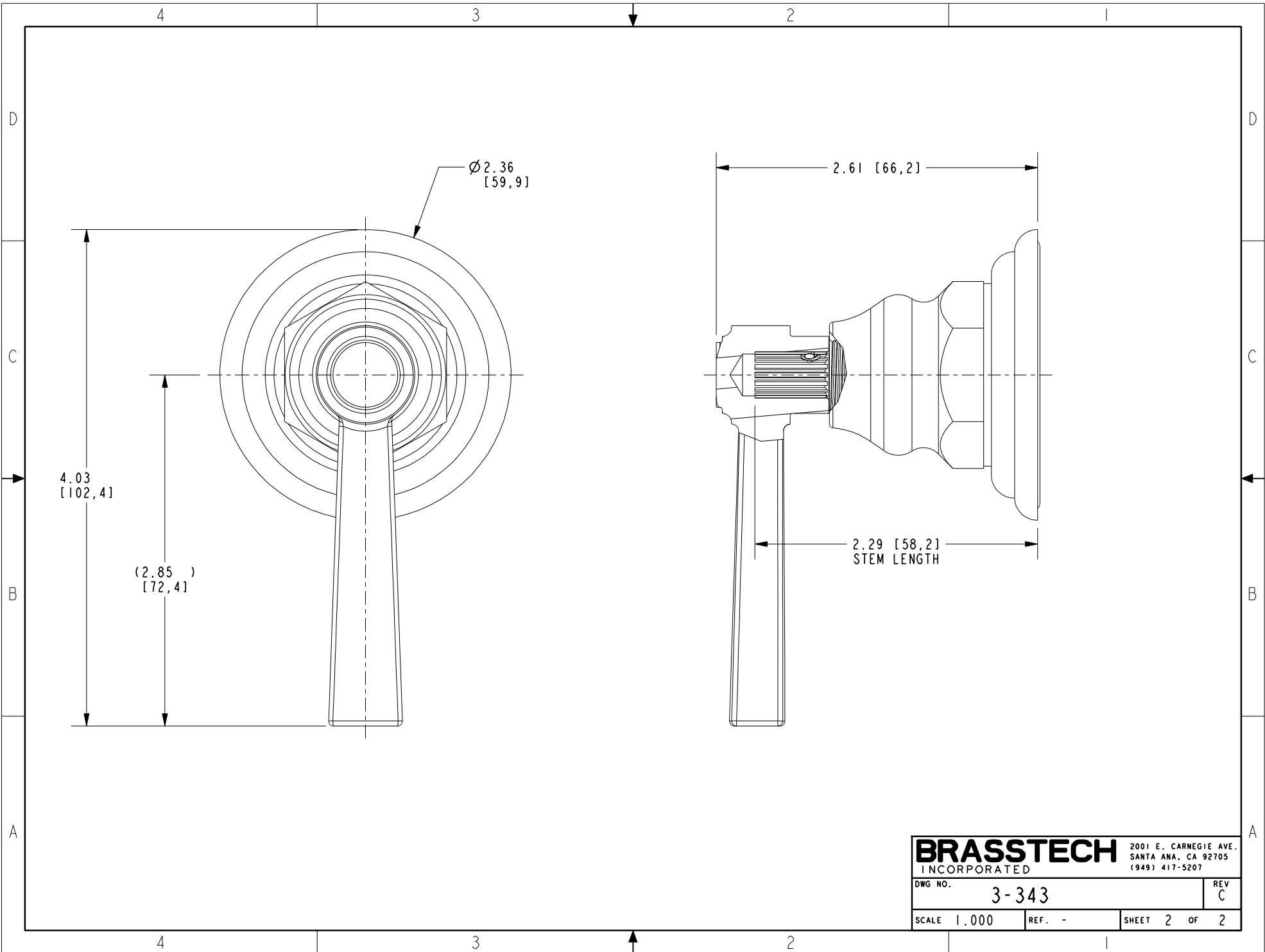

BRASSTECH		2001 E. CARNEGIE AVE. SANTA ANA, CA 92705 (949) 417-5207	
DWG NO.	3-343	REV	C
SCALE	1.000	REF.	-
		SHEET	2 OF 2